



SERVICE BULLETIN

Classification: EL01-001	Reference: NTB01-009	Date: February 9, 2001
-----------------------------	-------------------------	---------------------------

2001 MAXIMA ALARM SOUNDS AFTER 30 MINUTES AND/OR TRUNK LAMP INOPERATIVE

- APPLIED VEHICLES:** 2001 Maxima (A33)
APPLIED VINS: Vehicles built before: JN1CA31A*1T104331
 JN1CA31A*1T304531
 JN1CA31D*1T611224
 JN1CA31A*1T809711
APPLIED DATE: Vehicles built before September 22, 2000

SERVICE INFORMATION

If either of the following conditions exist on a 2001 Maxima:

- The anti-theft alarm activates 30 minutes after parking the vehicle when the map light is on, and the vehicle is locked. AND/OR
- The trunk lamp will not light when using the key to open the trunk 30 minutes after the ignition switch is turned off.

the cause may be the trunk room lamp circuit connection to the battery saver feature of the Smart Entrance Control Unit (SECU).

If either of the conditions described exist, perform the **Trunk Room Lamp Circuit Re-routing Procedure** in this bulletin to connect the trunk room lamp circuit directly to a battery circuit. A Sub-harness kit consisting of two wire tap connectors and a sub-harness wire is available to complete the re-route procedure.

When the trunk room lamp circuit re-route procedure is complete, use the **Confirmation Test** in this bulletin to verify the incident is resolved.

SERVICE PROCEDURE

Trunk Room Lamp Circuit Re-routing Procedure:

1. Record all radio station pre-sets.
2. Turn the ignition key to the OFF position, then disconnect the battery negative cable.

CAUTION: Move the cable far enough away from the battery to ensure it does not accidentally touch the post.

3. Remove the instrument under cover, driver's side (see Figure 1):

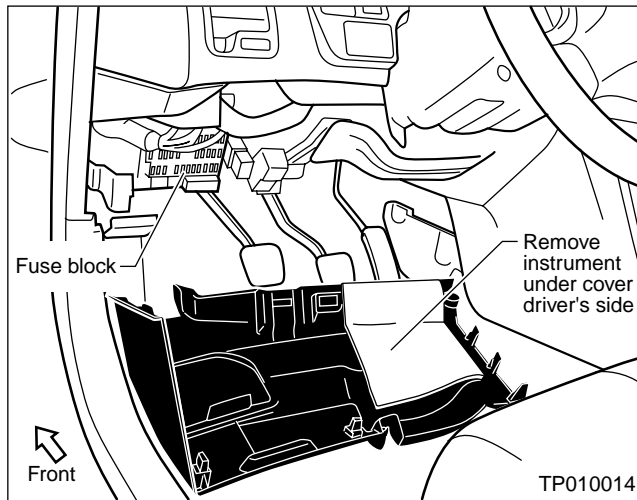

Figure 1

4. Disconnect the 3 Engine Room (EGI) harness connectors from the fuse block (see Figure 2).

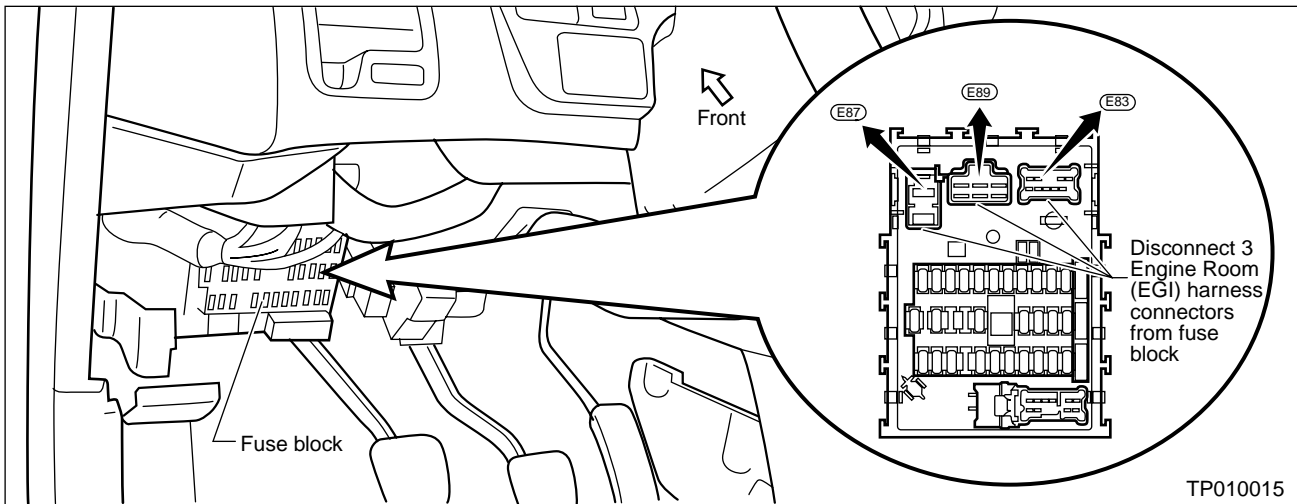

Figure 2

5. Remove the power window relay from the fuse block (see Figure 3).

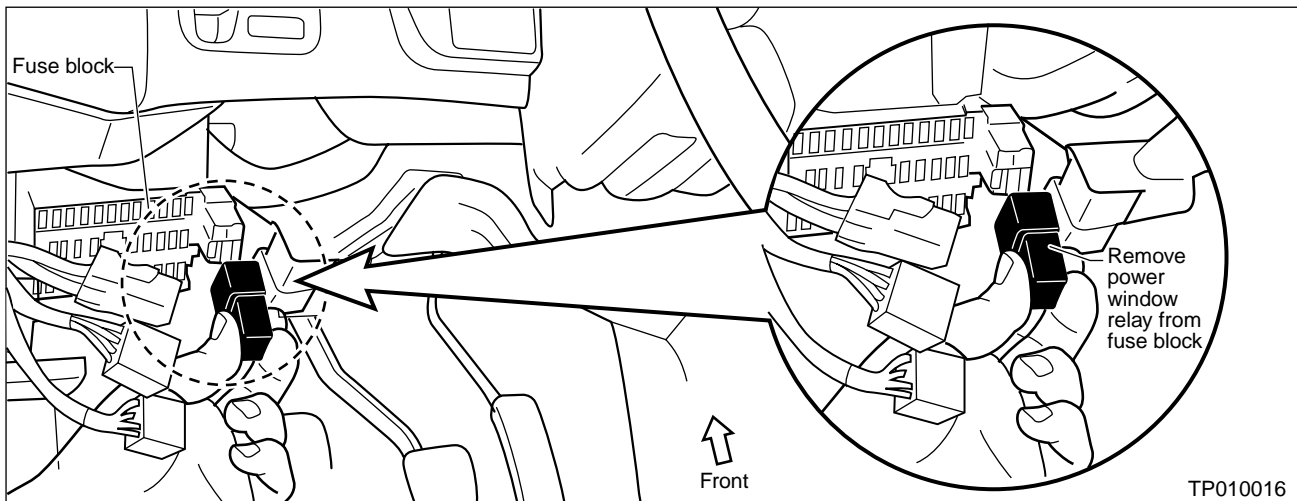

Figure 3

6. Remove the two screws which hold the fuse block to its' bracket.
7. Remove the fuse block from the bracket (see Figure 4).

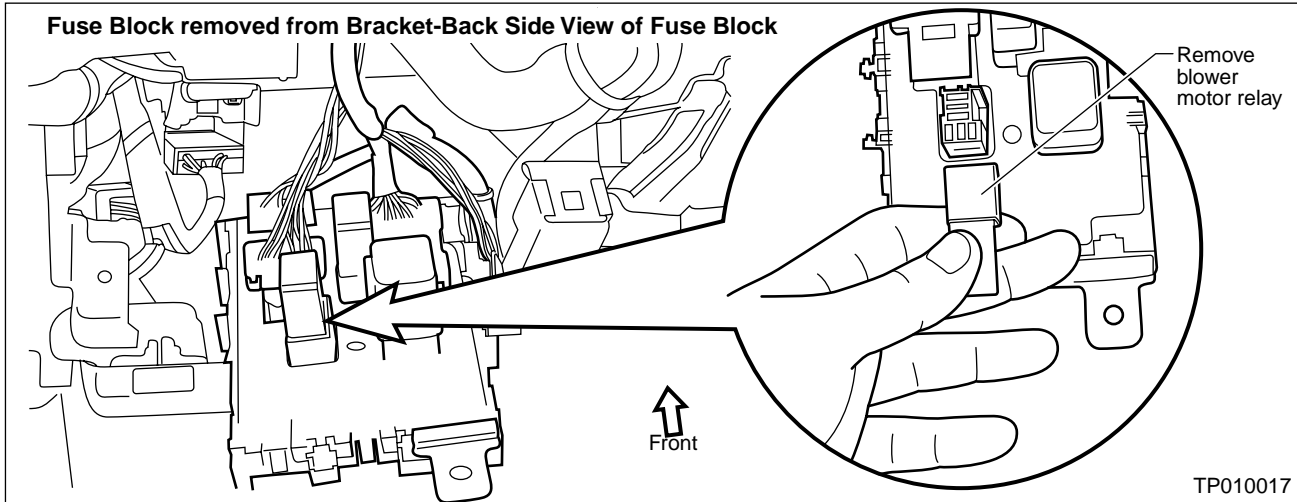

Figure 4

8. Remove the blower fan relay from the back side of the fuse block (see Figure 4).
9. Disconnect the 3 main harness connectors (M17, M18, and M19) from the back side of the fuse block (see Figure 5).

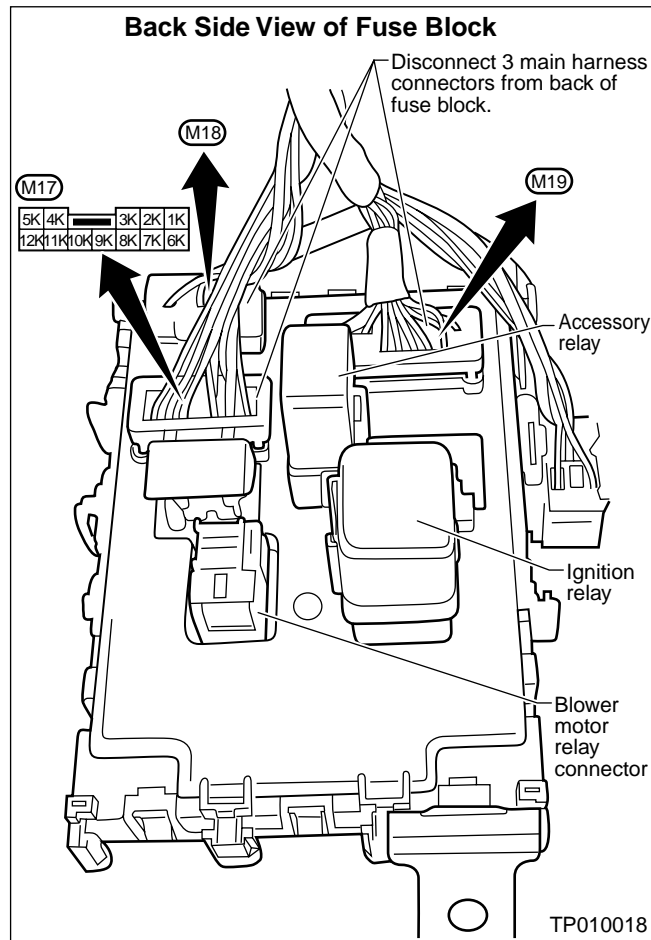

Figure 5

10. Disconnect the M2 connector (brown) from the B2 female end - see Figure 6.

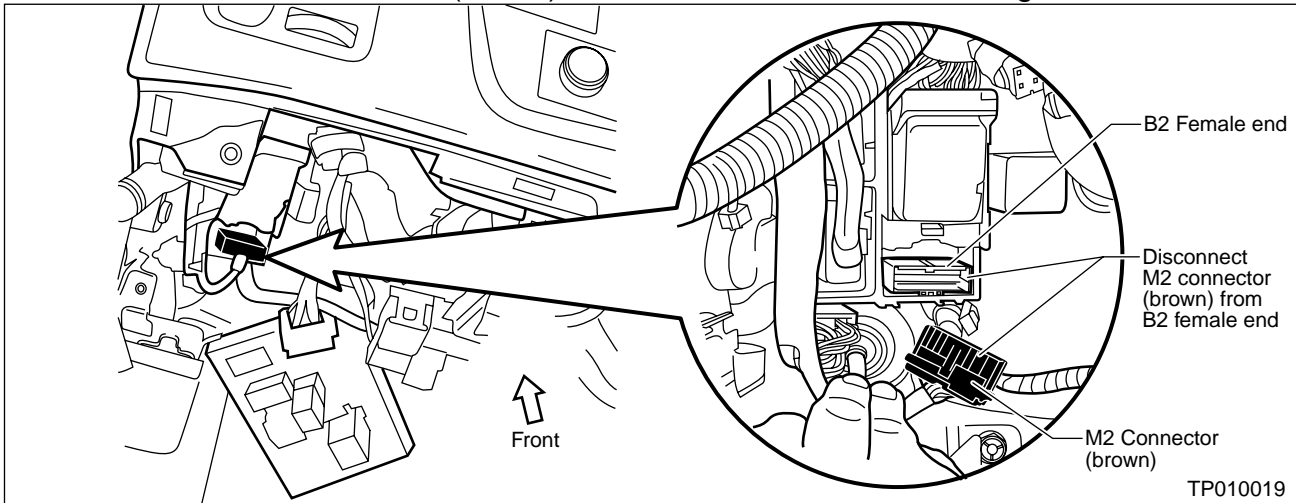

Figure 6

CAUTION: It is very important to identify the correct wires in the following steps. Before proceeding, review "How to Read Wiring Diagrams" in the GI section of the Service Manual. This gives information on wire color abbreviations and identifying connector pin locations.

NOTE: See Figure 7 for an overview of this repair:

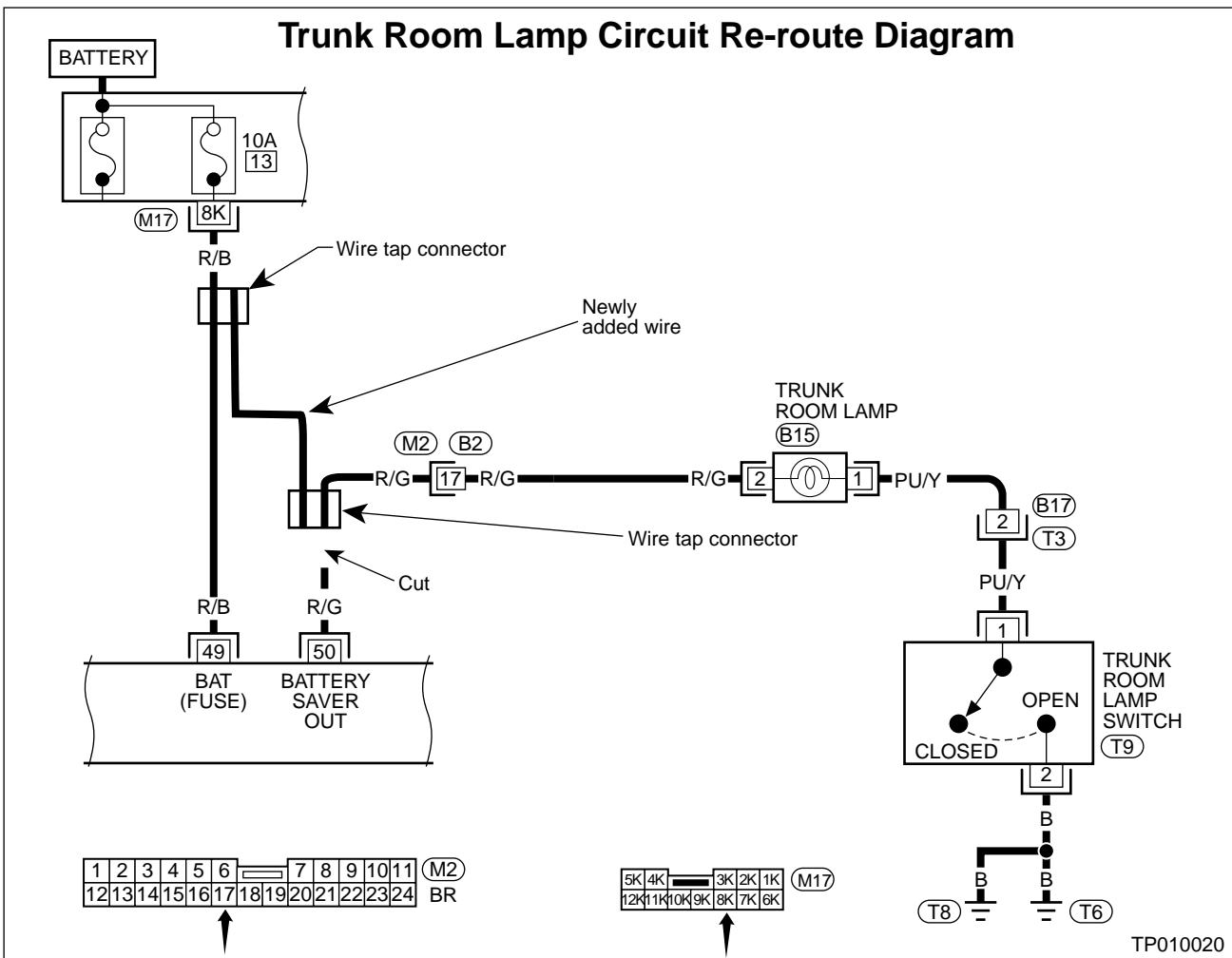

Figure 7

11. Locate the R/B wire (pin #8K) on the M17 main harness connector (white) which was disconnected in step 9 (see Figure 8).

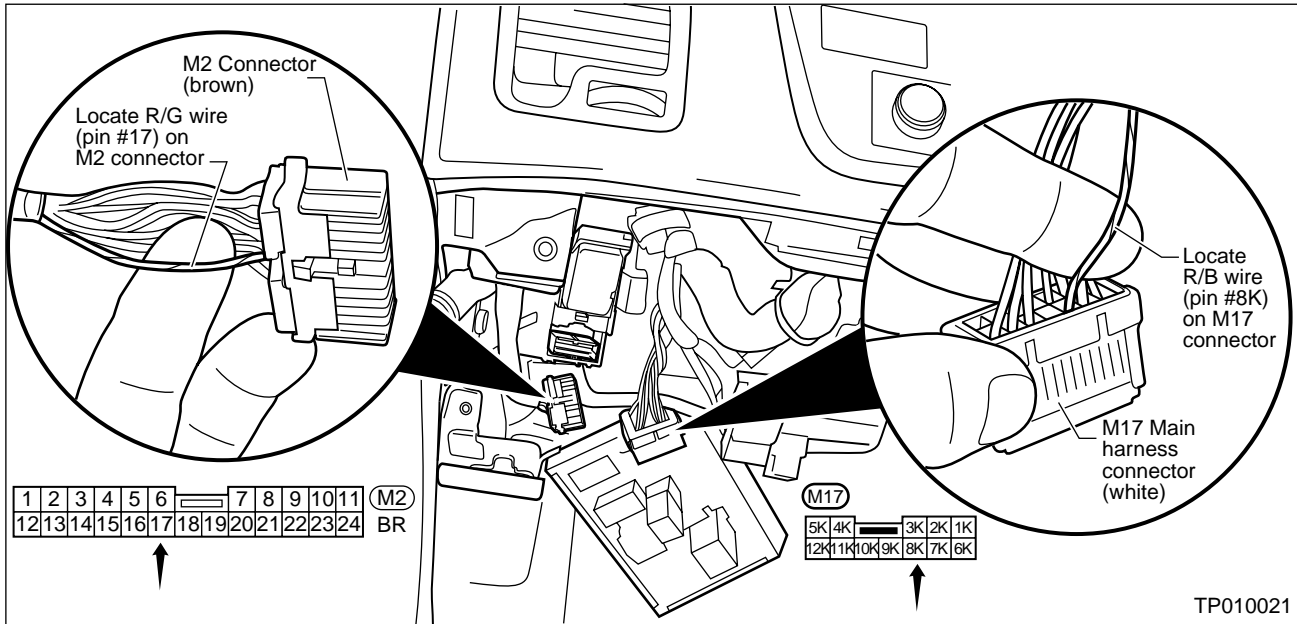

Figure 8

12. Locate the R/G wire (pin #17) on the M2 connector (brown) which was disconnected in step 10 (see Figure 8).

13. Cut the harness wrap surrounding the M2 connector wires back slightly more than 2 inches – 50 mm (see Figure 9).

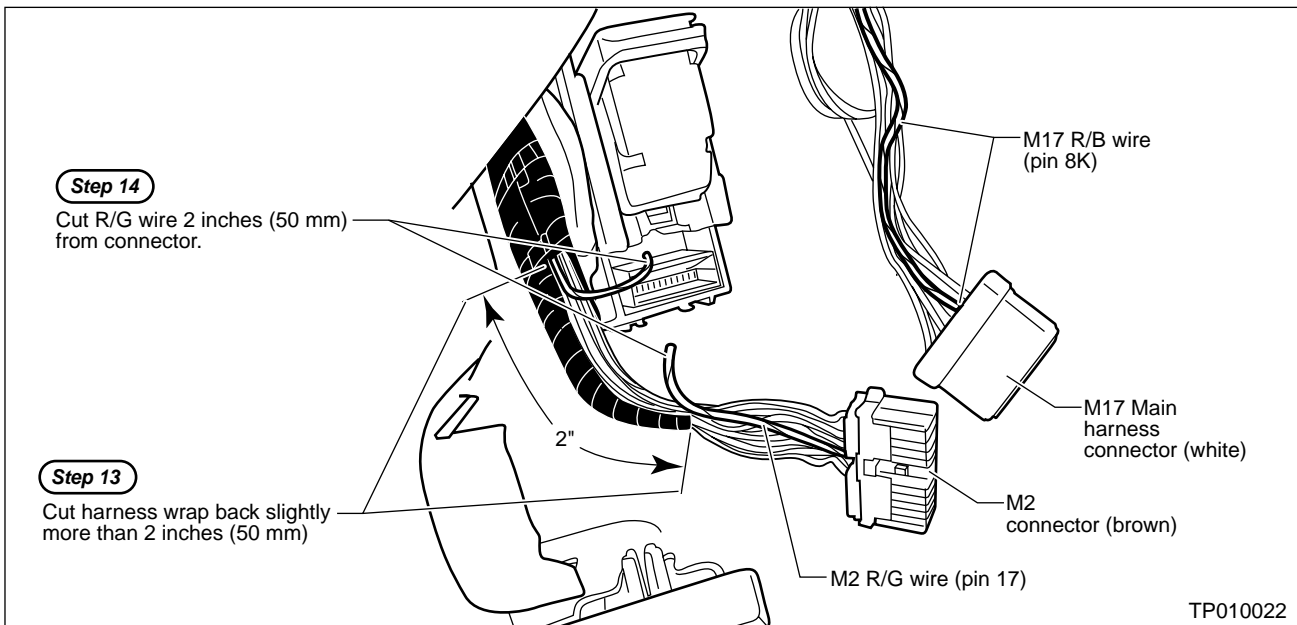

Figure 9

14. Cut the R/G wire on the M2 connector 2 inches (50 mm) from the connector (see Figure 9).

15. Attach the connector-side cut end of the R/G wire to one of the wire tap connectors provided in the sub-harness kit (see Figure 10).

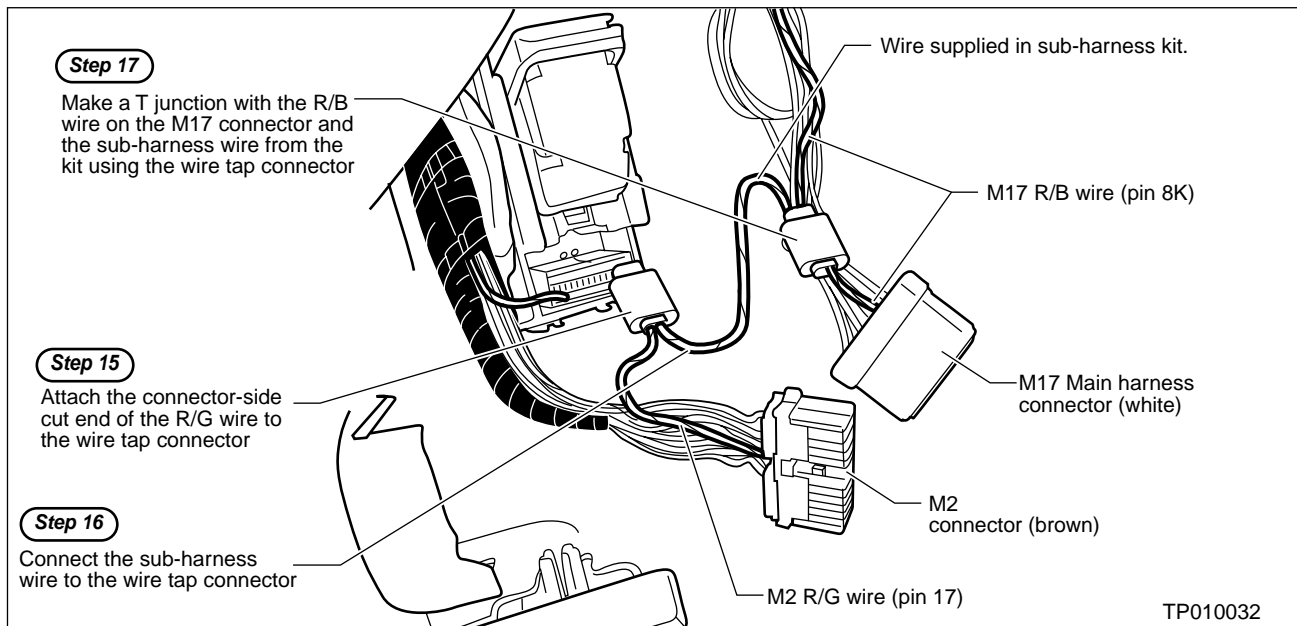

Figure 10

16. Connect one end of the sub-harness wire (provided in the sub-harness kit) to the wire tap connector attached to the R/G wire in step 15 (see Figure 10).
17. Make a T junction with the R/B wire located on the M17 connector and the other end of the sub-harness wire using the other wire tap connector provided in the sub-harness kit (see Figure 10).
18. Route the new sub-harness wire away from sharp edges or places it may be chafed.
19. Re-wrap the exposed wires of the M2 connector harness (including the harness-end cut R/G wire) with electrical tape.
20. Re-install all parts removed in reverse order.
21. Perform the following **Confirmation Test** to verify the incident is resolved.

Confirmation Test:

1. Reconnect the battery cable.
2. Close all doors.
3. Open the trunk with the key or remote and confirm that the trunk room lamp is on.
4. Close the trunk and wait 30 minutes.
5. Open the trunk after 30 minutes by using the key, **not the remote**, and confirm that the trunk room lamp is on.
6. Open the driver's-side front door and re-confirm the trunk room lamp is still on.
7. Verify that the remote works properly by locking and unlocking the doors, pushing the panic alarm button, and opening the trunk via the remote.
8. Re-program the radio station pre-sets.

PARTS INFORMATION

DESCRIPTION	PART #	QUANTITY
Harness, Sub-kit	24009-4Y900	1

CLAIMS INFORMATION

Submit a Primary Failed Part (PP) line claim using the following claims coding:

DESCRIPTION	PFP	OP CODE	SYM	DIA	FRT
Repair wiring harness	24009-4Y900	RA16AA	ZE	32	0.5 hrs.
